

## Wintegra Development System 2 (WDS2)

### WINPATH™ ACCESS PACKET PROCESSORS

#### Product Highlights

- Highly functional, integrated development systems for WinPath2 processors.
- System can be utilized for ATM, Ethernet and TDM software development, as well as demonstrations.
- Includes the state-of-the-art 300 MHz WinPath2.
- On-board support for four 10/100/1000 Ethernet. Copper Gigabit support is supplied via RJ45 connectors. Fiber support is available via SFP receptacles. (Fiber modules are not available from Wintegra.)
- 128 MB of Packet Bus memory, 200 MHz DDR2-SDRAM
- 4 MB of Parameter Bus memory, 200 MHz ZBT SRAM
- 16 MB of Host Bus memory, FLASH
- 128 MB of Application Bus memory, 200 MHz, DDR2-SDRAM
- 3 mezzanine-style connectors for use with WDS2 daughter cards
- Optional OC-3, OC12, Octal T1/E1 or PPC daughtercards
- Supports Wintegra UFE3 daughter card
- Additional 10/100 Ethernet port available for debug support
- 1 UART port
- I<sup>2</sup>C Serial EEPROM
- EJTAG connection
- WindRiver VxWorks or Linux BSPs available.



#### Wintegra Development System 2:

WDS2 is the integrated development system for WinPath2 customers. It is organized as a stand-alone board with optional plug-in cards.

The WDS2 is shipped with a 300 MHz WinPath2. This processor is the highest performing WinPath device to-date and can be software configured to represent any WinPath family member. It includes a MIPS 24Kc core for control path programming.

The WDS2 has on-board support for four 10/100/1000 Ethernet ports (copper connectivity supplied via RJ45 connectors), I<sup>2</sup>C, Boot Flash, EJTAG connectivity, a UART port, a dedicated 10/100 ethernet console port, and is populated with all three available WinPath2 memory buses.

The WDS2 guarantees maximum flexibility with its three available ports to support various combinations of the following plug-in cards: 16 port 10/100 WinNet board, 1 x OC12 (UTOPIA2/POS2), 4 x OC3 (UTOPIA2/POS2), 8 x E1/T1, UFE3, 60X/PCI bus extender.

Should a customer prefer to use the 60x (Power PC) card, the MIPS core in the WinPath2 can be disabled for PPC-based Control Plane Software systems. The PPC card utilizes high-density connectors connected to the WinPath2 60x bus.

Wintegra Development System 2

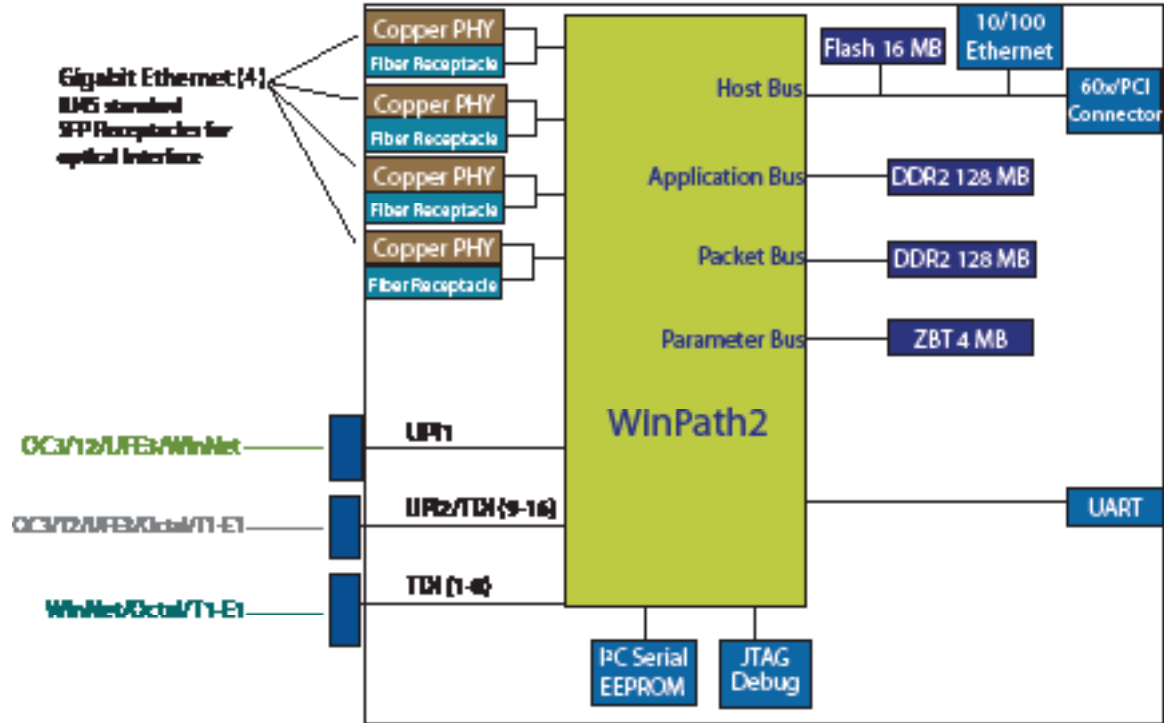

**Details:**

All three WinPath2 memory buses are populated on the WDS2. The Packet Bus has 128 MB of 32-bit wide DDR2 RAM operating at up to 200 MHz. The Parameter Bus has 4 MB of 64-bit ZBT SRAM also operating up to 200 MHz. The Host and Application Buses are populated with 16 MB of FLASH and 128 MB of 32-bit DDR2 SDRAM, running up to 200 MHz.

The WDS2 is supplied with Gigabit Ethernet copper PHY connectivity via four RJ45 ports. Alternatively, there are four SFP receptacles that can be used with multi-mode or single mode fiber modules, instead of the RJ45 ports. SFP fiber modules are not available from Wintegra, but we can reference several suppliers.

256 Kbit of I<sup>2</sup>C Serial EEPROM is available.

The dedicated 10/100 Ethernet port is useful as a console port, freeing up the other 10/100/1000 ports for data path operations.

**WDS Daughtercards:**

Various mezzanine cards are available in numerous configurations. The following daughter cards are available:

- 4x OC-3(UTPOIA/POS2 Serial Card
- UFE3
- WinNet (16 Fast Ethernet)
- OC-12 (UTOPIA/POS2 Serial Card)
- Octal T1/E1

Optionally, there is a PPC daughtercard that utilizes high-density connectors on the WinPath2 60x bus.

The WDS2 also supports the Wintegra UFE3 daughtercard. This card utilizes Wintegra's UFE3 FPGA, providing channelized STM4/OC-12 and up to 336/252 T1/E1 channels.



All Rights Reserved  
Printed in the United States of America  
All information contained in this document is subject to change without notice. The products in these documents are not intended for use in medical, life saving, or life support applications where malfunction may result in injury or death to persons. Wintegra may make changes to specifications or product descriptions at any time, without notice.  
The information supplied by this document is provided on an "AS IS" basis. In no event will Wintegra be liable for damages arising directly or indirectly from any use of the information contained in this document. Wintegra® is registered in the United States Patent and Trademark Office  
For more information, see [www.wintegra.com](http://www.wintegra.com).  
PBWDS - 0207 - AM